

PROPRIETARY AND CONFIDENTIAL  
 THE INFORMATION CONTAINED IN THIS DRAWING IS THE SOLE PROPERTY OF MARKS DESIGN AND METALWORKS, LLC. ANY REPRODUCTION IN PART OR AS A WHOLE WITHOUT THE WRITTEN PERMISSION OF MARKS DESIGN AND METALWORKS, LLC IS PROHIBITED.

0			
1			
2			
3			

		PARTS LIST				
ITEM	PART NUMBER	DESCRIPTION	QTY	MATERIAL	APPEARANCE	MASS
1		BALL VALVE, NPT, 1/4"	2	304 S/S		
2		CLAMP & GASKET, 8"	1			
3		PRESSURE GAUGE, 0-30 PSI, 2.5 INCH FACE, .25 MNPT, BOTTOM	1			
4		WELDMENT, BODY, HOP DOSER	1			
4-1		FERRULE, TC, 4" OD X 7/8" OAL	1			
4-2		REDUCER, WELD, CONCENTRIC, 8" X 4"	1			
4-3		FERRULE, TC, 8" OD X 9.5" OAL	1			
4-4		HALF COUPLER, NPT, 1/4"	1			
4-5		HANDLE, .25 ROUND, 5 X 2.5	2			
4-6		TUBE, 8" OD X .065" WALL, 10-3/8" OAL	1			
5		WELDMENT, CAP, HOP DOSER	1			
5-1		CAP, TC, 8"	1			
5-2		HALF COUPLER, NPT, 1/4"	2			

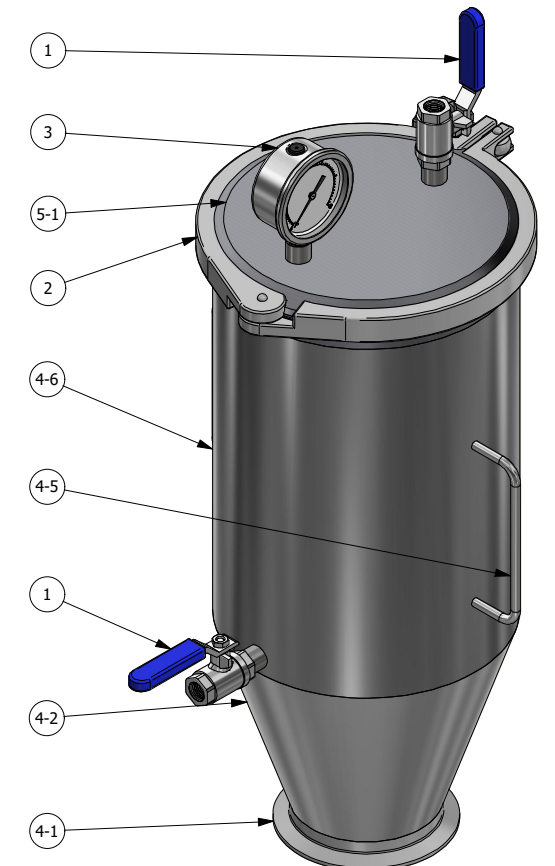
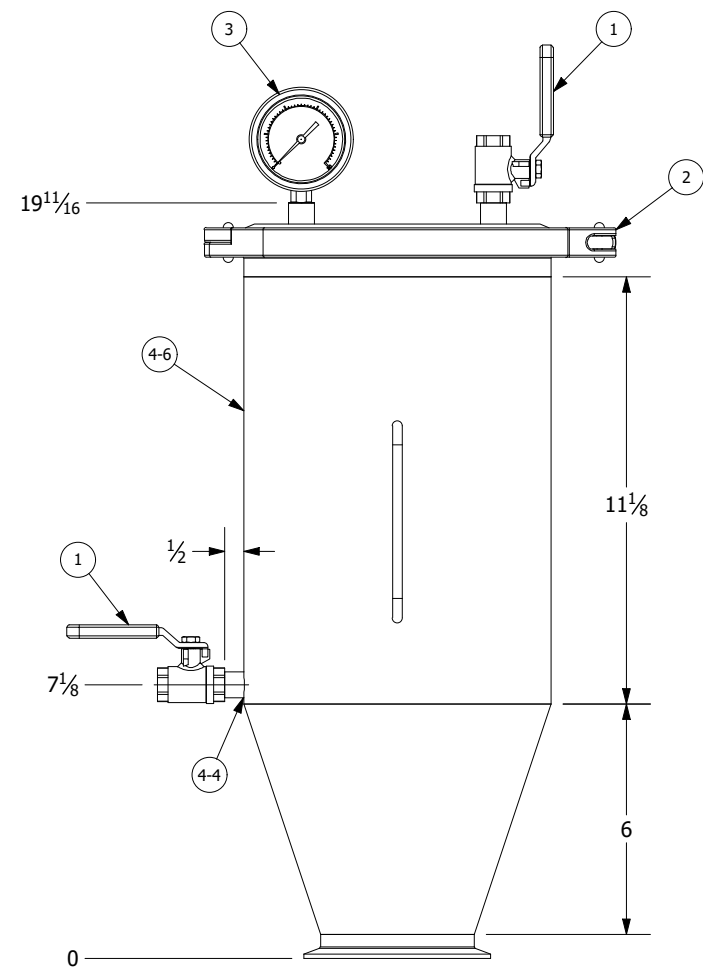
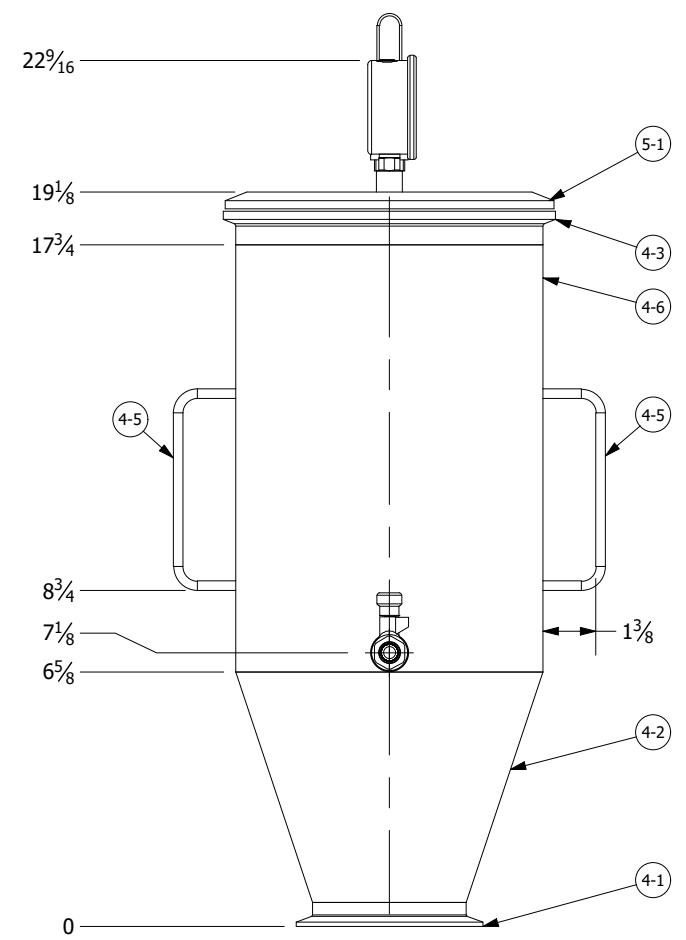
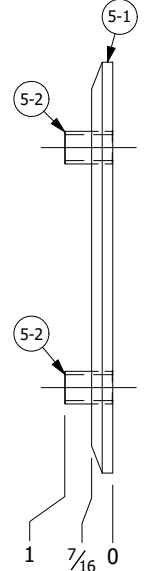
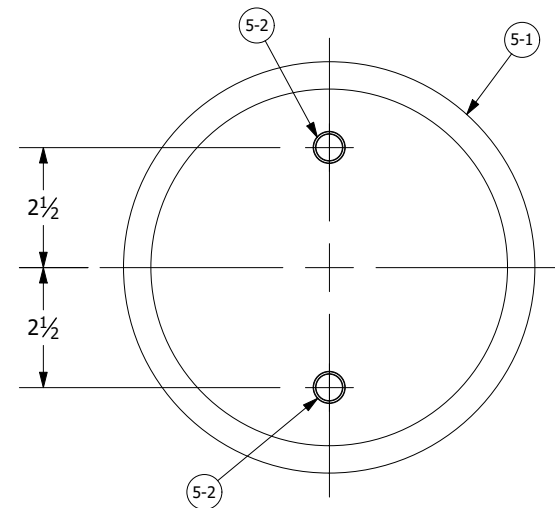

NOTES:  
 VOLUME: 3 GAL  
 WEIGHT: 22 LBS (EMPTY), 33 LBS (FULL)

UNLESS OTHERWISE SPECIFIED:		NAME	DATE		<b>TITLE:</b> FULL HOP DOSER	<b>S/N#</b> W101180	
DIMENSIONS ARE IN INCHES		AUTHOR	D.GUTHRIE				3/4/2021
TOLERANCES		CHECKED					
Fractional: 1/8" Angular ±1° Bend ±2" 1 Decimal (.x): ±0.1" 2 Decimal (.0x): ±0.03" 3 Decimal (.00x): ±0.005"		ENG APPR.					
MACHINE FINISH		MFG APPR.			<b>DWG.</b> W101180	<b>REV</b> 3	
PROJECTION		Q.A.					
MATERIAL:		COMMENTS:			<b>SCALE:</b> 1/5	<b>WEIGHT:</b> N/A	
FINISH:							<b>SHEET</b> 1 of 1
DO NOT SCALE DRAWING							