

PROPRIETARY AND CONFIDENTIAL
 THE INFORMATION CONTAINED IN THIS
 DRAWING IS THE SOLE PROPERTY OF MARKS
 DESIGN AND METALWORKS, LLC. ANY
 REPRODUCTION IN PART OR AS A WHOLE
 WITHOUT THE WRITTEN PERMISSION OF
 MARKS DESIGN AND METALWORKS, LLC IS
 PROHIBITED.

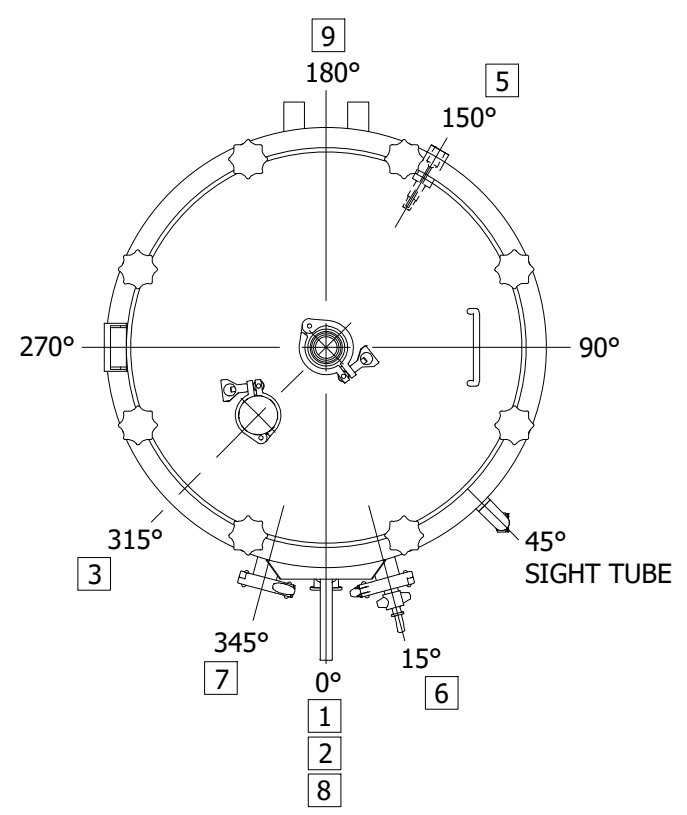

FOOT PAD DETAIL

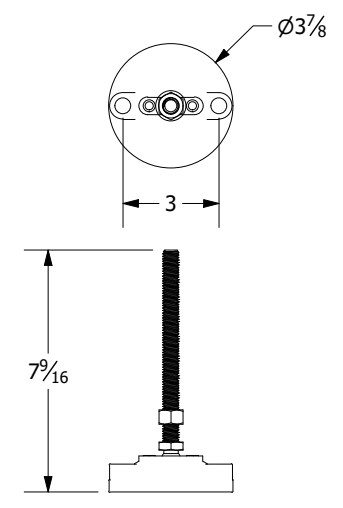

DIMENSIONS						
BBL	A	B	C	WEIGHT (EMPTY)	WEIGHT (WORKING)	WEIGHT (FULL)
1	Ø17-1/2"	52"	14-9/16"	300 lbs	550 lbs	600 lbs
2	Ø23-1/2"	57-7/8"	19-3/4"	400 lbs	870 lbs	1,000 lbs
3	Ø23-1/2"	77-3/4"	19-3/4"	450 lbs	1,250 lbs	1,450 lbs

REVISION HISTORY				
REV	DESCRIPTION	DATE	REV ID	APPROVED
A	INITIAL		D.G.	

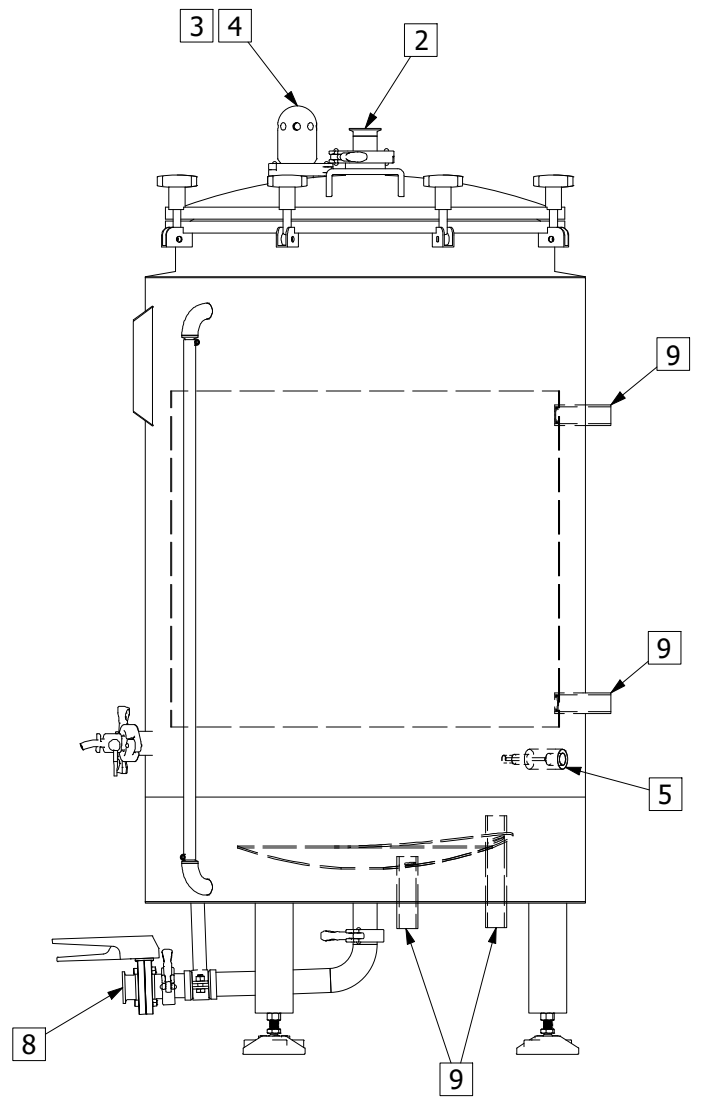
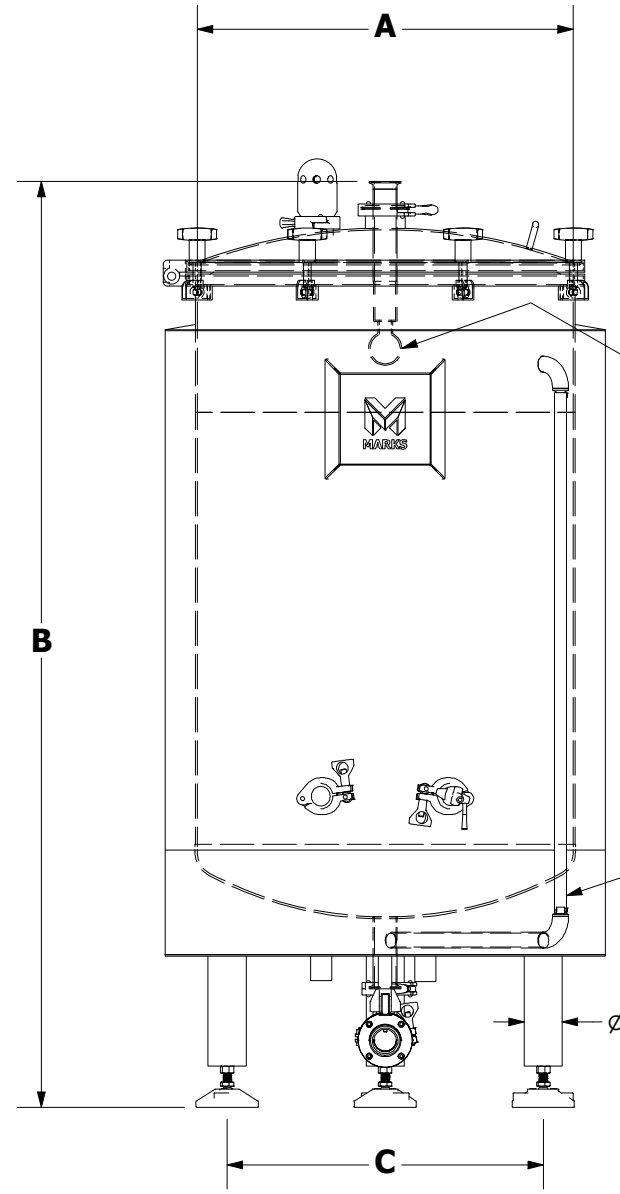

FEATURES							
IDENTIFIER	SERVICE	QTY	LOCATION	NECK SIZE	NECK TYPE	CONNECTION SIZE	CONNECTION TYPE
1	MANWAY	1	SHELL TOP	SEE TABLE ABOVE	ROUND	N/A	N/A
2	CIP	1	MANWAY	1-1/2"	TUBE	1-1/2"	TC
3	CO2	1	MANWAY	1-1/2"	TUBE	2"	TC
4	PVRV	1	MANWAY	2"	N/A	2"	TC
5	THERMOWELL	1	SHELL SIDEWALL	1"	PIPE	1/2"	FNPT
6	SAMPLE	1	SHELL SIDEWALL	1-1/2"	TUBE	1-1/2"	TC
7	CARB	1	SHELL SIDEWALL	1-1/2"	TUBE	1-1/2"	TC
8	DRAIN	1	BOTTOM DISH	1-1/2"	TUBE	1-1/2"	TC
9	GLYCOL	2/ZONE	JACKET	1"	PIPE	1"	MNPT

UNLESS OTHERWISE SPECIFIED:		NAME	DATE
DIMENSIONS ARE IN INCHES		AUTHOR	D.GUTHRIE
TOLERANCES		CHECKED	
Fractional: 1/8"		ENG APPR.	
Angular: ±1° Bend ±2°		MFG APPR.	
1 Decimal (x): ±0.1"		Q.A.	
2 Decimal (xx): ±0.03"		COMMENTS:	
3 Decimal (xxx): ±0.005"			
MACHINE FINISH	PROJECTION		
MATERIAL:			
FINISH:			
DO NOT SCALE DRAWING			

TITLE: SINGLE RING BRITE BEER TANK, TOP MANWAY

S/N#

DSC. 2 RING SERIES

SIZE B

DWG. D200001 - D200003

REV A

SCALE: DO NOT SCALE

WEIGHT: N/A

SHEET 1 of 2

PROPRIETARY AND CONFIDENTIAL
 THE INFORMATION CONTAINED IN THIS
 DRAWING IS THE SOLE PROPERTY OF MARKS
 DESIGN AND METALWORKS, LLC. ANY
 REPRODUCTION IN PART OR AS A WHOLE
 WITHOUT THE WRITTEN PERMISSION OF
 MARKS DESIGN AND METALWORKS, LLC IS
 PROHIBITED.

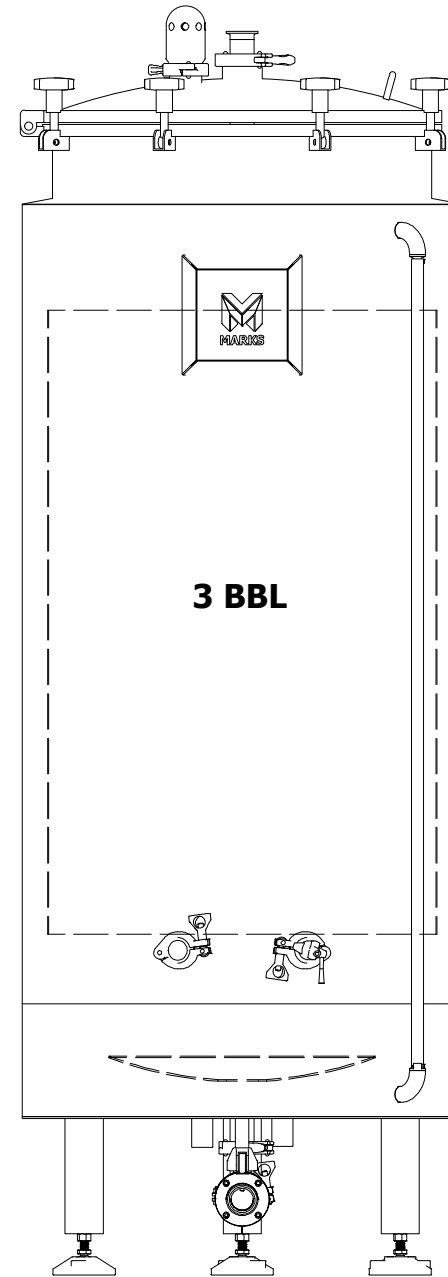
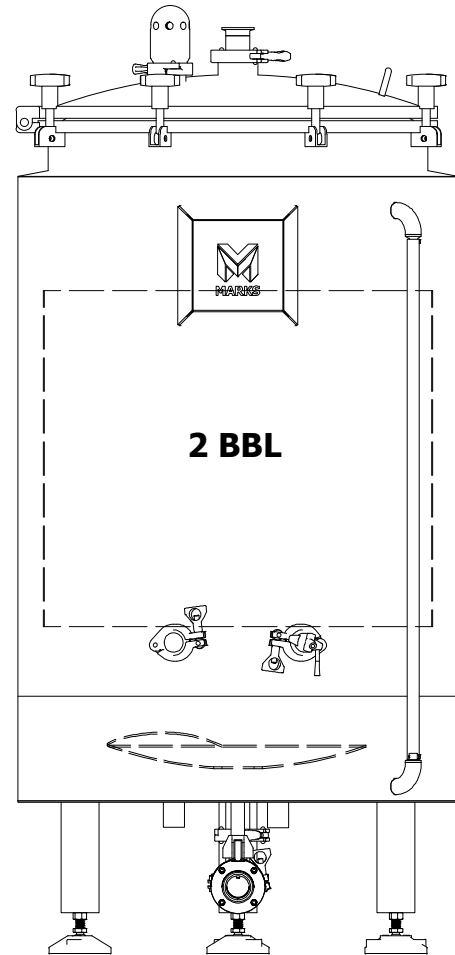
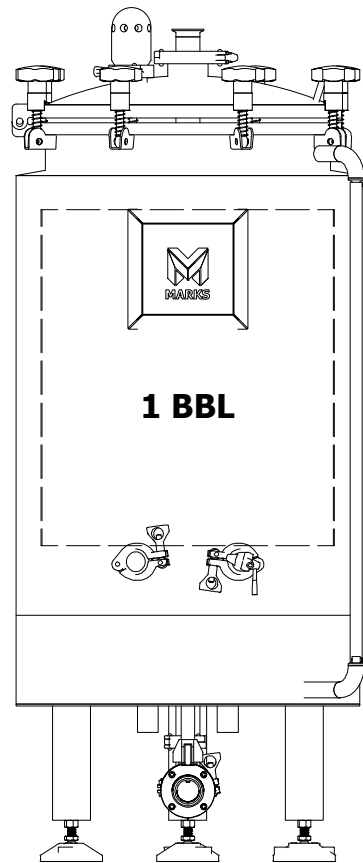

*COOLING ZONES SHOWN WITH HIDDEN LINES

UNLESS OTHERWISE SPECIFIED:		NAME	DATE				
DIMENSIONS ARE IN INCHES		AUTHOR	D.GUTHRIE				
TOLERANCES		CHECKED					
Fractional: 1/8"		ENG APPR.					
Angular ±1° Bend ±2°		MFG APPR.					
1 Decimal (x): ±0.1"		Q.A.		TITLE: SINGLE RING BRITE BEER TANK, TOP MANWAY			
2 Decimal (.0x): ±0.03"		COMMENTS:		S/N#			
3 Decimal (.00x): ±0.005"				DISC.	TANK LINEUP	SIZE B	
MACHINE FINISH	PROJECTION			DWG.	D200001 - D200003	REV	
				SCALE:	DO NOT SCALE	WEIGHT:	N/A
MATERIAL:		DO NOT SCALE DRAWING					
FINISH:							