

PROPRIETARY AND CONFIDENTIAL
 THE INFORMATION CONTAINED IN THIS
 DRAWING IS THE SOLE PROPERTY OF MARKS
 DESIGN AND METALWORKS, LLC. ANY
 REPRODUCTION IN PART OR AS A WHOLE
 WITHOUT THE WRITTEN PERMISSION OF
 MARKS DESIGN AND METALWORKS, LLC IS
 PROHIBITED.

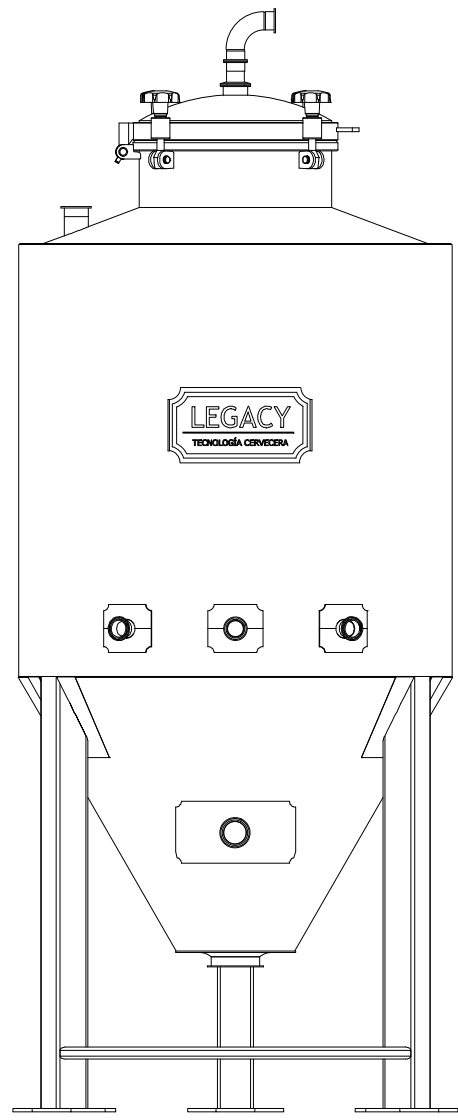
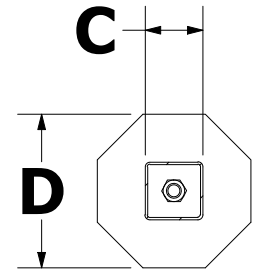
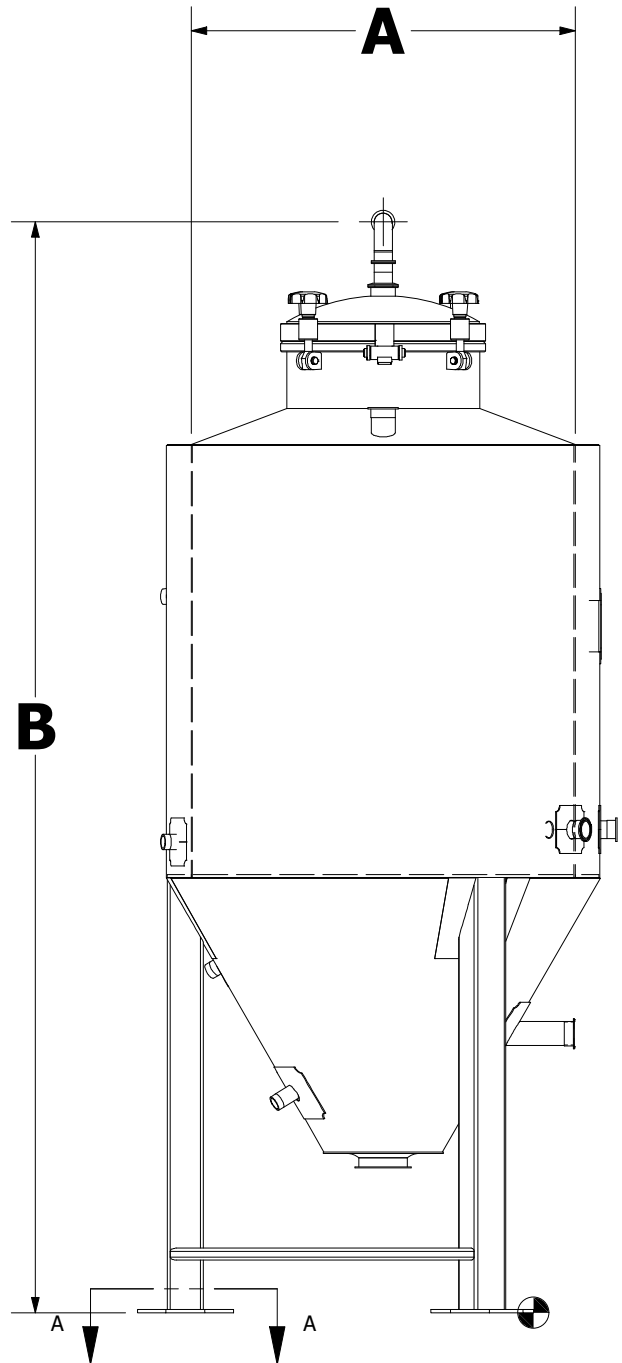
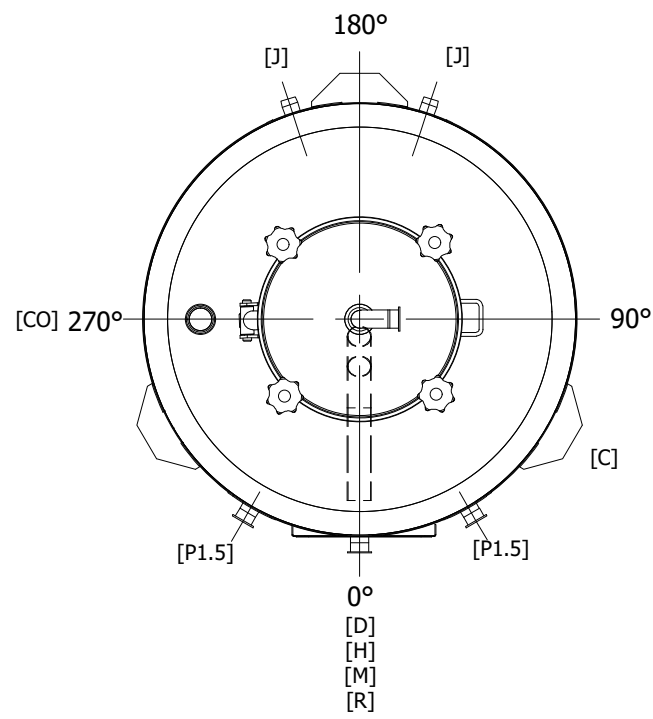

DIMENSIONS								
BBL	MAX VOL (BBL)	A	B	C	D	WEIGHT (EMPTY)	WEIGHT (WORKING)	WEIGHT (FULL)
1	1.25	20"	57-1/2"	2"	8	300	550	600
2	2.5	24"	75-1/2"	3"	8	400	950	1,100

REVISION HISTORY				
REV	DESCRIPTION	DATE	REV ID	APPROVED
A	LEGACY STANDARD	04/19/2022	D.G	

ADDITIONAL COMPATIBLE PARTS

1. MANWAY GASKET: M16P011

NOZZLE SCHEDULE							
IDENTIFIER	SERVICE	QTY	LOCATION	NECK SIZE	NECK TYPE	CONNECTION SIZE	CONNECTION TYPE
C	CIP	1	TOP HEAD	2"	TUBE	1-1/2"	TC
CO	CO2	1	TOP HEAD	1-1/2"	TUBE	1-1/2"	TC
D	DRAIN	1	BOTTOM CONE	4"	TUBE	4"	TC
H	DRY HOP	1	TOP HEAD	4"	TUBE	4"	TC
J	GLYCOL	4	JACKETS	1"	PIPE	1"	MNPT
M	MANWAY	1	TOP HEAD	16"	ROUND	N/A	N/A
R	RACKING ARM	1	SHELL CONE	2"	TUBE	2"	TC
P1.5	1-1/2" PORT	3	SHELL SIDEWALL	1-1/2"	TUBE	1-1/2"	TC

REVISION APPROVED: **A** SIZE APPROVED: _____ BBL

CUSTOMER SIGNATURE: _____ DATE: _____

UNLESS OTHERWISE SPECIFIED:		NAME	DATE	
DIMENSIONS ARE IN INCHES		AUTHOR	D. GUTHRIE	
TOLERANCES		CHECKED		
Fractional: 1/8"		ENG APPR.		
Angular ±1° Bend ±2°		MFG APPR.		
1 Decimal (x): ±0.1"		Q.A.		TITLE: LEGACY FV SERIES
2 Decimal (.0x): ±0.03"		COMMENTS:		S/N#
3 Decimal (.00x): ±0.005"		1. JACKET MAX PRESSURE: 14.9 PSI		SIZE B
MACHINE FINISH		2. JACKET TEST PRESSURE: 20 PSI		REV A
PROJECTION		3. TANK MAX PRESSURE: 14.9 PSI		DWG.
MATERIAL:		DO NOT SCALE DRAWING		SCALE:
FINISH:				WEIGHT:
				SHEET 1 of 1